



# High Performance Silver ZEBRA Connector

ZEBRA is registered Trademarks of FUJIPOLY in USA, Canada, UK, Hong Kong, Thailand and Shingapore.

**FUJIPOLY DATA SHEET NUMBER FPDS 01-34 / Version 7**

## **Fuji Polymer Industries Co.,Ltd.** (Overseas office)

**JAPAN**

FUJIPOLY Bldg., 5-21-1, Meieki, Nakamura-ku, Nagoya, Aichi, 450-0002 Japan

[Phone] +81-52-589-9251 [Web site] <https://www.fujipoly.co.jp/> [E-mail] [sales@fujipoly.co.jp](mailto:sales@fujipoly.co.jp)

ISO9001 / IATF16949(Aichi Plant)

## **Fuji Polymer Industries Co.,Ltd. Korea Liaison Office**

**SOUTH KOREA**

A-404, 97 Yeouidong-ro, Youngdeungpo, Seoul, 07324, Korea

[Phone] +82-2-785-2801 [Web site] <https://fujipoly.co.kr/> [E-mail] [info@fujipoly.co.kr](mailto:info@fujipoly.co.kr)

## **Fujipoly Taiwan Co., Ltd.**

**TAIWAN**

Room B, 7F., No. 59, Tiansiang Rd.,Jhongsan District, Taipei City 10452, Taiwan

[Phone] +886-2-2586-5771 [Web site] <http://www.fujipoly.com.tw/> [E-mail] [fujipolytw@fujipoly.com.tw](mailto:fujipolytw@fujipoly.com.tw)

## **Fujipoly America Corporation**

**USA**

900 Milik Street P.O. BOX 119 Carteret, NJ 07008-0119, USA

[Phone] +1-732-969-0100 [Web site] <https://www.fujipoly.com/> [E-mail] [info@fujipoly.com](mailto:info@fujipoly.com)

ISO9001 / IATF16949

## **Fujipoly Customer Engineering Resource Center**

**USA**

94 Bonaventura Drive, San Jose, CA, 95134

[Phone] +1-408-708-5980 [E-mail] [fpcerc@fujipoly.com](mailto:fpcerc@fujipoly.com)

## **Fujipoly Europe Ltd.**

**UK**

Avant Business Centre, Unit 8, Third Avenue, Bletchley Milton Keynes, MK1 1DR UK

[Phone] +44-1908-277800 [Web site] <https://www.fujipoly.eu/> [E-mail] [sales@fujipoly.eu](mailto:sales@fujipoly.eu)

## **Fujipoly Europe Ltd. Germany Liaison Office**

**GERMANY**

[Phone] +49-7156-9278310

[Web site] <https://www.fujipoly.eu/> [E-mail] [support.germany@fujipoly.eu](mailto:support.germany@fujipoly.eu)

## **Fujipoly (Thailand) Co.,Ltd.**

**THAILAND**

55/8 Moo 13 Navanakorn Industrial Estate Phase 4, Phaholyothin Road.Klong Nueng,Klong Luang,Pathumthanee 12120, Thailand

[Phone] +66-2-529-2732 [E-mail] [marketing@fujipoly.co.th](mailto:marketing@fujipoly.co.th)

ISO9001 / ISO14001 / IATF16949

## **Fujipoly Singapore Pte Ltd.**

**SINGAPORE**

1001 Jalan Bukit Merah #02-17/20 Singapore 159455

[Phone] +65-6272-3766 [Web site] <https://www.fujipoly.sg> [E-mail] [info@fujipoly.com.sg](mailto:info@fujipoly.com.sg)

ISO9001

## **Fujipoly Hong Kong Ltd.**

**HONG KONG**

Workshop(F&J),Block1,4/F.,Kwai Tak Industrial Centre,15-33 Kwai Tak Street,Kwai Chung,N.T.,Hong Kong.

[Phone] +852-2428-3770 [E-mail] [info@fujipoly.com.hk](mailto:info@fujipoly.com.hk)

## **Fujipoly Trading (Shenzhen) Co.,Ltd.**

**CHINA**

Room 2703, Diwang Commercial Building, Shunhing Square, 5002 Shennan East Road, Luohu District, Shenzhen, 518022, China

[Phone] +86-755-8237-5494 [Web site] <http://www.fujipoly.net.cn> [E-mail] [info@fujipoly.com.hk](mailto:info@fujipoly.com.hk)

## **Fujipoly China (Dongguan) Electronics Co.,Ltd.**

**CHINA**

Gaobao Road 10, Tutang Estate, Changping, Dongguan, Guangdong, 523581, China

[Phone] +86-769-8398-9660 [E-mail] [info@fujipoly.com.hk](mailto:info@fujipoly.com.hk)

ISO9001 / ISO14001

	Page
<b>1] Product Name.</b> .....	<b>- 02 -</b>
<b>2] Features.</b> .....	<b>- 02 -</b>
<b>3] Variety of High Performance Connector. (Figure -1,2)</b> .....	<b>- 03 -</b>
<b>4] Available Size and Tolerance.(Table-2)</b> .....	<b>- 04 -</b>
<b>5] Design Recommendations.</b> .....	<b>- 04 -</b>
<b>6] Dimentional Specificatioious.(Table-3)</b> .....	<b>- 04 -</b>
<b>7] Typical Product Properties.(Table-4)</b> .....	<b>- 04 -</b>
<b>8] Typical Material Properties.(Table-5)</b> .....	<b>- 05 -</b>
<b>9] Calculation of Resistance and Force Defiection(Table-6)</b> .....	<b>- 05 -</b>
<b>10] Others</b> .....	<b>- 06 -</b>
<b>11] Trade Marks</b> .....	<b>- 06 -</b>

- Attention -

- 1) High Performance Silver ZEBRA  
SZ100 Type. 0.100mm Pitch  
FUJIPOLY DATA SHEET FPDS 01-34



# DATA SHEET

FPDS 01- 34 (Version 7)

## 1] Product Name :

High Performance Silver ZEBRA Connector.(SZ100 / 0.10mm pitch)

## 2] Features :

FUJIPOLY High performance Silver ZEBRA connectors are constructed of alternating parallel layers of electrically conductive and nonconductive silicone elastomer. The electrically conductive layer is filled with silver-metal particles.

The composite alternating layers provide reliable electrical connection when placed between two aligned conducting surfaces.

The High Performance Silver ZEBRA Connector provides a redundant connection with a minimum of two conductive layers recommended per PCB contact pad. The connector is available with insulating barrier or silicone supports. The connectors are used for connecting electroluminescent ( EL ) and plasma type displays to PC boards or for connecting hybrid circuits to PC boards, among other applications.

The High Performance Silver ZEBRA connector is positioned between two aligned surfaces and is mechanically clamped together with a lid or another PCB. The connectors may be free standing or positioned in a retainer depending on packaging profiles and design.

**3] Variety of High Performance Silver ZEBRA Connector.**

**3] -1) Insulation Barrier Type ( Figure 1 )**

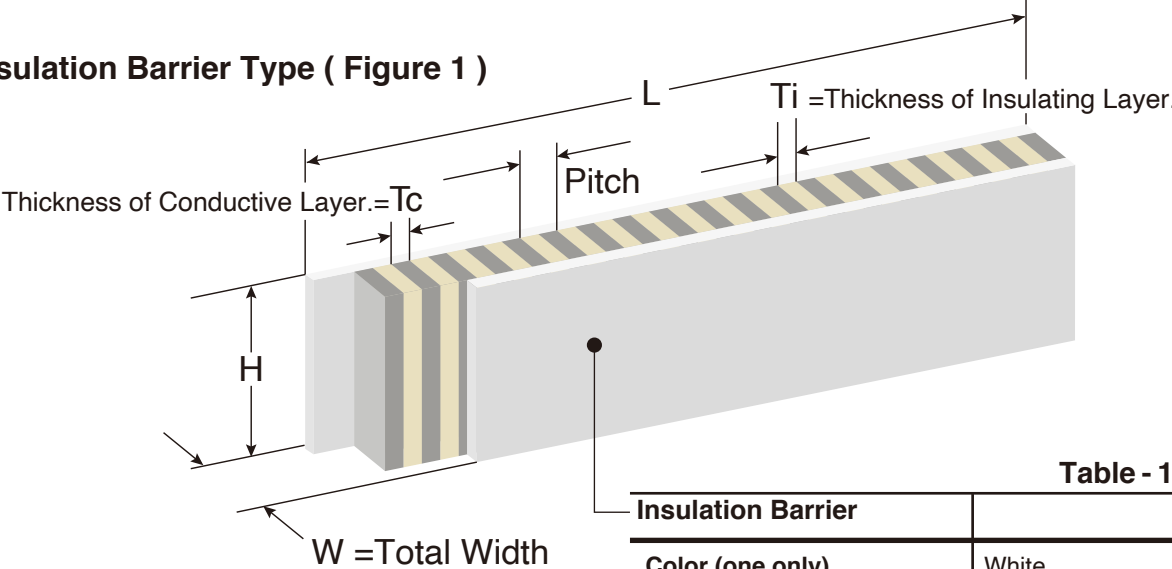

**Table - 1**

Insulation Barrier	
Color (one only)	White
Thickness	0.002"(0.05mm)
Dielectric Strength	500 Volts/mil
Resistance (ohms)	10 <sup>12</sup>

**3] -2) Insulation Silicone Support Type ( Figure 2 )**

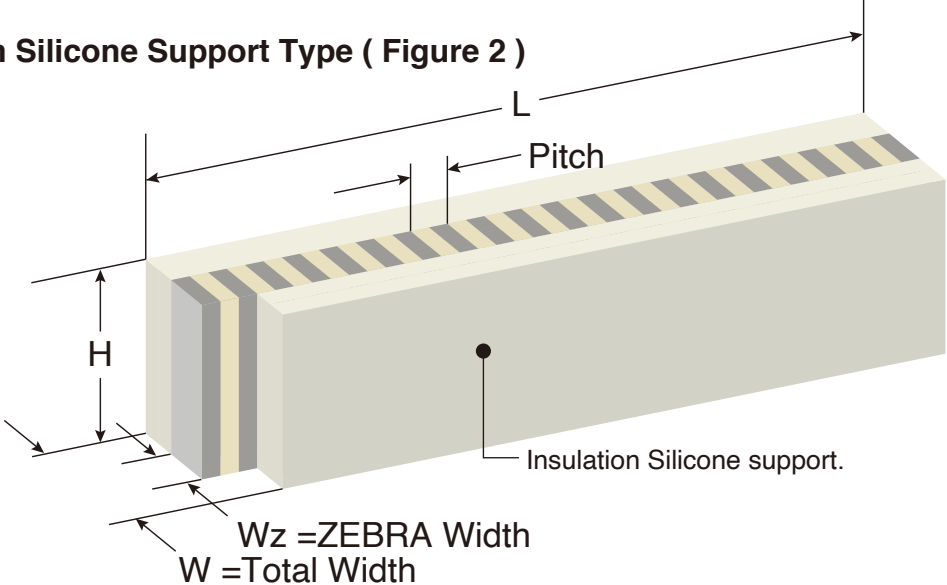

#### 4] Available Size and Tolerance.

Table - 2

Mesurement	Mark	MM : Size and Tolerance	inche : Size and Tolerance
Length	L	6.35mm ± 0.12 ~ 127.00mm ± 0.64	0.250" ± 0.005in ~ 5.000" ± 0.025in
Heigh	H	1.00mm ± 0.08 ~ 12.70mm ± 0.18	0.040" ± 0.003in ~ 0.500" ± 0.007in
Width	W	0.50mm ± 0.08 ~ 2.54mm ± 0.13	0.020" ± 0.003in ~ 0.100" ± 0.005in

#### 5] Design Recommendations.

Recommended deflection range is 5-25% of free height. Minimum deflection will vary with packaging applications and should consider overall height, PCB warpage, finish, etc.

Design recommendations for Solid type and Insulation Barrier type over 10.00mm deflect 1.27mm maximum. Insulation silicone support type. Over 10.00mm defect 1.50mm.

The use of an insulating barrier type or silicone self-support material on one or both sides of the connetor is recommehded. The silicone support is utilized to reduce clamp force and provide an element of environmental protection for a cost-effective connection.

Table - 3

6] Dimentional Specifications.		MM	inch
Contact Spacing Center - to -Center	Minimum	0.050	0.002
	No minal	0.100	0.004
Pich : Sum of the thickness of an adjacent conductive and Insulation layer	Maximum	0.150	0.006
	No minal	10 <sub>Line/mm</sub>	254 <sub>Line/inch</sub>
Individual conductive and Insulation Layer Thinckness	Minimum	0.030	0.001
	Maximum	0.075	0.003

#### 7] Typical Product Properties.

Table - 4

Operating Temperature Range	Minimum	-40°C ( -40°F )
	Maximum	+85°C ( +185°F )
Current Carrying Capacity	700 mA/mm <sup>2</sup>	1.0mm Pitch ( 0.50mm / 0.50mm )
Resistance Between Layers	10 <sup>12</sup> ohms	

## 8] Typical Material Properties.

Table - 5

Item Unit	Conductive Layer	Insulating Layer	Support Rubber
material	Silver Filled Silicone Rubber	Non-conductive Silicone Rubber	Non-conductive Silicone Rubber
Color	Silver Gray	Off-white	Light blue
Hardness Shore A	80	58	30
Tensile Strength MPa	2.0	7.7	4.0
Elongation %	120	380	400
Tear Strength KN/m	13	17	–
Volume Resistivity MΩ·m	1x10 <sup>-12</sup>	1x10 <sup>6</sup>	1x10 <sup>6</sup>

## 9] Calculation of Resistance and Force Deflection.

### 9] -1) Resistance

For the purpose of calculating the resistance of High Performance Silver ZEBRA Connector and testing them for compliance please use the following formula :

Table - 6

MM ( Metric )

$$R = \frac{H \times 0.01}{W \times Ew} + 0.10$$

Where :

R = Resistance in ohms.

W = Width of ZEBRA Portion (mm)

Ew = Electrode Pad width (mm)

H = Height of ZEBRA Portion (mm)

For the purpose of calculating the resistance of SZ Connector and testing them for compliance please use the formula.

### 9] -2) Force Deflection

Connector should be deflection 10 to 15% of Height (H) to calculate for deflection, use following formula.

#### Insulation Barrier Type.

$$F = (10.0 \times D \times W \times L) \times 9.8 \times 10^{-3}$$

#### Insulation Silicone Support Type.

$$F = [(10.0 \times D \times W \times L) + \{1.8 \times D \times (W - W_1) \times L\}] \times 9.8 \times 10^{-3}$$

Where : F = Force : N

$$D = \frac{H - H_1}{H} \times 100\%$$

H = Height of Connector ( mm )

H<sub>1</sub> = Deflected height of Connector ( mm )

W = Width of Connector ( mm )

W<sub>1</sub> = Width of ZEBRA Portion ( mm )

L = Length of Connector ( mm )

## 10] Others

FUJIPOLY website <http://www.fujipoly.com/>

## 11] Trade Marks



in USA and UK

# ZEBRA

### Notes :

- All FUJIPOLY test data in this document is based on FUJIPOLY test method and is believe to be accurate and reliable. Nevertheless, any FUJIPOLY test data shows typical product properties, and does not show the guaranteed product properties.
- Some Silicone oil could exude from the product according to operating conditions.
- Some low molecular Siloxane could vaporize from the product according to operating conditions.
- It is advisable to use the product under recommended operating condition. Some more Silicone oil could exude from the product if it was used over the recommended condition.
- It is advisable to use the product under parallel and even compression. Some more Silicone oil could exude from the product if it was used under excessive or partial stress.
- Products testing by the purchaser is recommended in order to meet expected results such as performance and application.

: March.24th 2023	version 7
: April.18th 2008	version 6
: January.16th 2006	version 5
: September.1st 2005	version 4
: February.14th 2003	version 3
: January.31th 2002	version 2
ISSUED : January.12th 2001	version 1

**STATEMENT OF LIEU OF WARRANTY:** All technical information and data in this document is based on tests and is believed to be accurate and reliable. Nevertheless, since the products described herein are not provided to conform with mutually accepted specifications and the use thereof is unknown, the manufacturer and seller of the product do not guarantee results, freedom from patent infringement, or suitability of the product for any application thereof. The manufacturer and seller of the product, described in this document will provide all possible technical assistance and will replace any products proven defective. No statement or recommendation made by the manufacturer or seller, not contained herein, shall have any force of effect unless in conformity with an agreement signed by an officer of the seller or manufacturer. Product testing by the purchaser is recommended in order to confirm expected results.

Copyright 2023 FUJIPOLY.

**FUJIPOLY** is registered Trademarks of FUJIPOLY Group.